



austofix CHN

CANNULATED HUMERAL NAIL LONG

Surgical Technique

Antegrade



Contents

| | |
|--|----|
| Introduction | 3 |
| Design Details | 4 |
| • Materials | 4 |
| • Nails | 4 |
| • Screws | 5 |
| Indications & Pre-Operative Planning | 6 |
| Patient Positioning | 7 |
| Incision. | 7 |
| Bone Preparation. | 8 |
| Nail Length | 8 |
| Instrument Assembly | 9 |
| Nail Insertion. | 10 |
| Insertion of Screws | 11 |
| • Distal Screws | 11 |
| • Ezy-Aim Distal Targeting | 11 |
| • Proximal Screws. | 12 |
| Aftercare | 14 |
| Nail Extraction | 15 |
| • Screw Removal | 15 |
| • Nail Removal. | 15 |
| Instruments. | 16 |
| Implants - Titanium | 18 |
| MRI Safety. | 19 |

Disclaimer

This document is intended to be read by experienced orthopaedic trauma surgeons familiar with Intramedullary Nailing of the long bones.

This publication is intended as the recommended procedure for using the Austofix Nailing system. It offers guidance only. Each surgeon should consider the particular needs of the patient and make appropriate adjustments where necessary.

For further advice please contact your local Austofix representative.
© This document is copyright to Austofix Pty Ltd, and may not be reproduced in whole or part without permission.

Introduction

Austofix is an Australian medical device manufacturer and distributor specialising in orthopaedic trauma. Since 1993, Austofix has designed, manufactured and marketed its range of implants throughout the world.

In collaboration with Australian surgeons, Austofix has introduced innovative, cost-effective implant systems that improve patient outcomes whilst supporting safe and efficient operating procedures. Austofix continues to develop its range of products through collaboration with new expertise, technologies and partnerships with surgeons and scientific institutions.

austofixCHN CANNULATED HUMERAL NAIL

There is now a broad variety of specialised proximal humeral fixation devices on the market. The Austofix CHN stands out as one of very few having a lengthy and well proven clinical history. The design dates back to pioneering Humeral Nail research in the early 1990s. Austofix was the first to introduce obliquely angled and “locked” screws through its Humeral Head Screw anti-backout feature. Independent bioengineering research has since confirmed that the unique characteristics of the Austofix CHN implant provides superior

Austofix products are distributed globally from our offices based in Thebarton, Australia. Our well-trained product specialists and customer service staff are available for all customer enquiries and product support and understand the needs of the orthopaedic market.

Austofix is dedicated to excellence in every aspect of medical device design, manufacture and product service.

strength and rigidity when compared to other devices. These advantages may be the deciding factor in the successful healing of marginal osteoporotic multi-part fractures.

In 2006 Austofix has further improved this very successful product. By enabling precise positioning of the Humeral Head Screws and introducing smaller incremental sizes, the fixation device is making direct contact with the best quality subchondral bone.

Design Details

CHN Long

The CHN Long provides fixation options for fractures extending more than 90mm from the top of the humerus. Indicated for any fracture extending down the mid-shaft, and/or shaft fractures in isolation. The CHN Long can be inserted antegrade or retrograde.

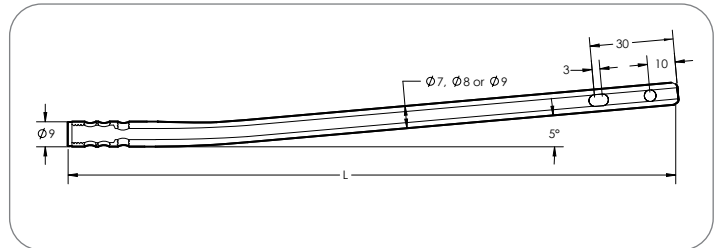

Materials

All implants are made from ISO 5832-3 Titanium made specially to Austofix specifications. This metal gives unrivalled strength and rigidity. Austofix insists on very tight tolerances which result in a high quality design which is narrower.

The company has been successfully making Humeral Nails to these demanding specifications since the early 1990s. This enables the insertion "footprint" to be the smallest possible, thus preserving the rotator cuff and enabling early mobilisation which makes full use of the device's great strength and stability. Independent cadaver testing has shown the Austofix CHN construct to be superior to a well known proximal humeral plate design.

Nails

The Austofix CHN Long is designed for fractures in the middle and distal shaft. It is available in lengths of 180-280mm (in 20mm increments). The CHN Long features a distal hole for static locking and a slot for dynamic locking.

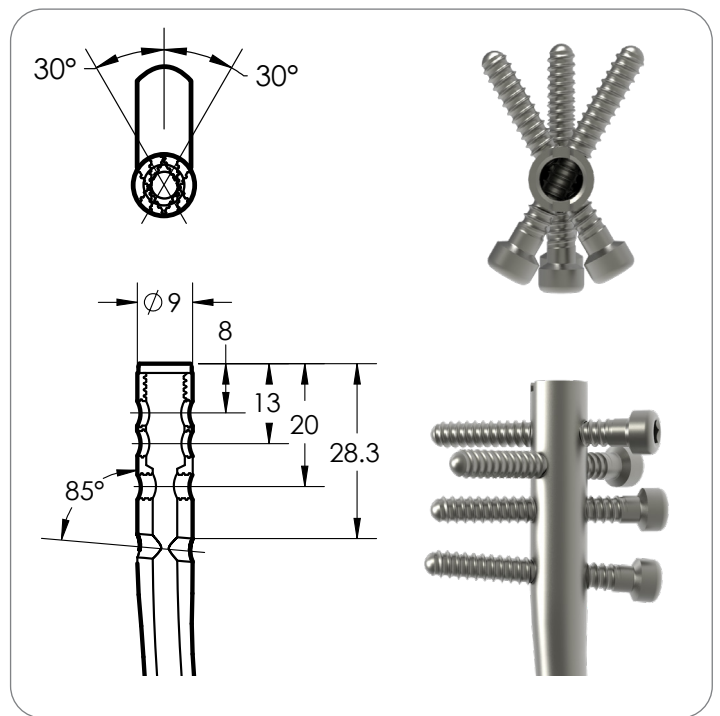

Screws

3.5mm/4.0mm Nail Locking Screws

Used for distal locking, these Screws feature a special thread design with 75% of the thread being shallow facilitating insertion and the final 25% expanding to grip the first cortex.

4.3mm Humeral Head Screws

Used in the four proximal holes of the CHN, these Screws contain an anti-backout mechanism and are securely placed in a tapped proximal hole in the Nail. The Screws feature blunt contact tips with low profile heads and incremental 2.5mm sizes are offered to enable the closest possible placement to the subchondral bone.

Note: The two distal holes will not admit the Humeral Head Screws.

Humeral Nail End Cap is available in the following lengths 1, 5, 10, 15, 20mm

The Titanium Washer (134301) for Humeral Head Screws can be used to lag fragments to the humeral head and for greater tuberosity fractures.

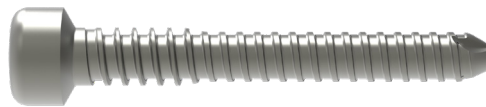

3.5mm Nail Locking Screw
(Ø7mm Nail)

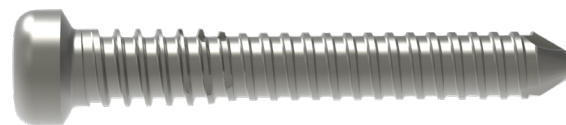

4.0mm Nail Locking Screw
(Ø8mm & Ø9mm Nails)

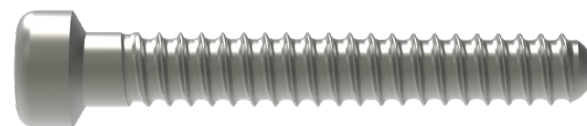

4.3mm Humeral Head Screw

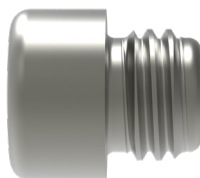

Humeral Nail End Cap

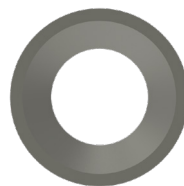

Washer for Humeral Head Screws



Indications & Pre-Operative Planning

CHN Long

This Nail provides fixation options for fractures extending more than 90mm from the top of the humerus. Indicated for any fracture extending down the mid-shaft, and/or shaft fractures in isolation.

It can also be inserted retrograde (see separate booklet, CHN Long Retrograde Insertion). This avoids transgressing the rotator cuff but it is a more difficult technique.



Patient Positioning

The patient lies supine near the side of the operating table, with the shoulder and arm lying on a radiolucent board.

Check that the A-P and oblique X-ray views of the shoulder are obtainable (true lateral views are not necessary). The arm is draped so that free shoulder and elbow movements are possible.

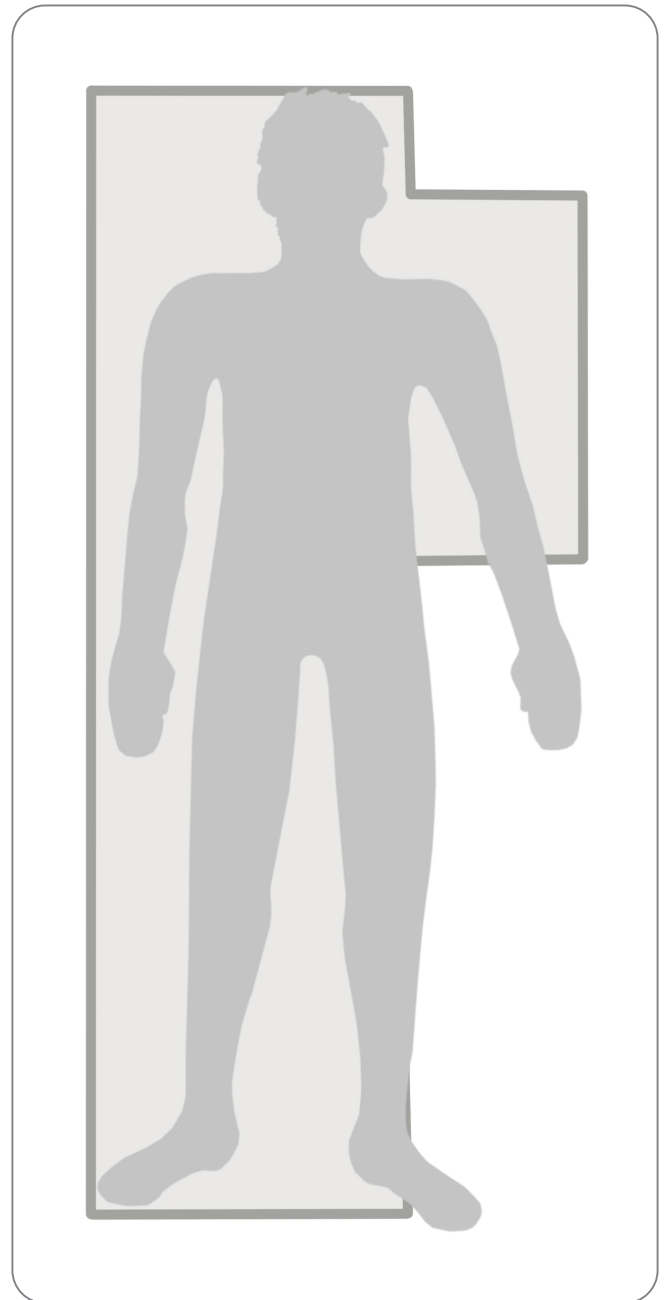

Incision

- A short antero-lateral deltoid splitting incision is used, and the rotator cuff is incised for 1-1.5cm in the line of its fibres. This technique minimises soft tissue disruption and ensures the patient can benefit from early mobilisation.
- A full deltopectoral exposure is necessary for displaced non-unions or comminuted fractures requiring open reduction.

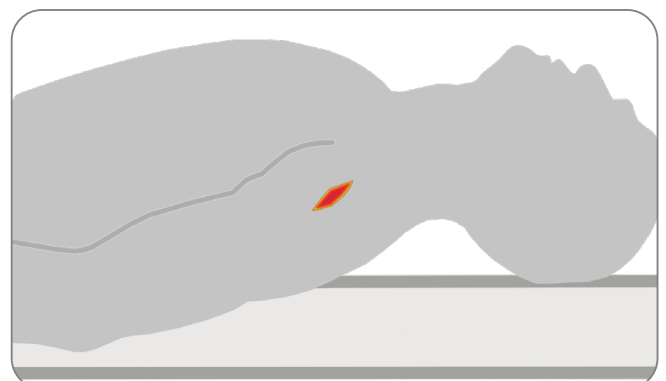

Bone Preparation

Entry Point

- At lateral edge of articular margin.
- 1 - 1.5cm behind the bicipital groove (Figure a).
- In comminuted fractures, the entry hole can be more medial, in the articular surface if necessary or making use of the fracture lines.

Drilling

- Pass the 9mm Cannulated Drill Reamer (520921) over a 2.5x250mm K-Wire (512525) with the 10mm Tissue Guard (600001). Hold the Tissue Guard against the bone and slowly advance the Drill Reamer for approximately 50mm, frequently checking alignment on X-ray (Figure b).

Hand Reaming

- Use the 8mm Hand Reamer (600008), checking on X-ray that it is in line with the medullary canal (Figure c).
- Finally pass the reamer across the fracture site to the 180mm depth marking.
- For diaphyseal fractures, ensure the tip of the CHN Long will be well past the middle-third of the humerus to minimise risk to the radial nerve during distal Screw placement.
- Pass the reamer to the position for the Nail, note the depth mark at the rotator cuff, and subtract 10mm to determine the Nail length.

Powered Flexible Reaming*

- For distracted fractures, the use of a 8.0mm Flexible Reamer (543080) is advised. With the Tissue Guard (600001) against the bone, insert a 3.0x900mm Ball-tip Guidewire (533900) to the depth intended for the Nail (Figure d). If it cannot be passed across the fracture, ream the proximal fragment first and insert the Guidewire Director (600079) to the fracture site. Rotate and manipulate the Guidewire Director to align the Ball-tip Guidewire with the distal fragment.

Note: The Humeral Nail Length Gauge (600069) must be used following the Powered Flexible Reaming process (Page 9).

Note: If the Guidewire is excessively bent, it may need to be changed to a new, straight wire after reaming.

*Flexible Reamer Instrument Set (SET-INS-REAM) supplied on request.

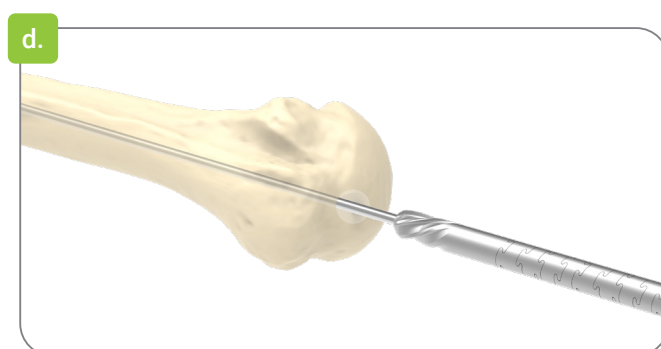
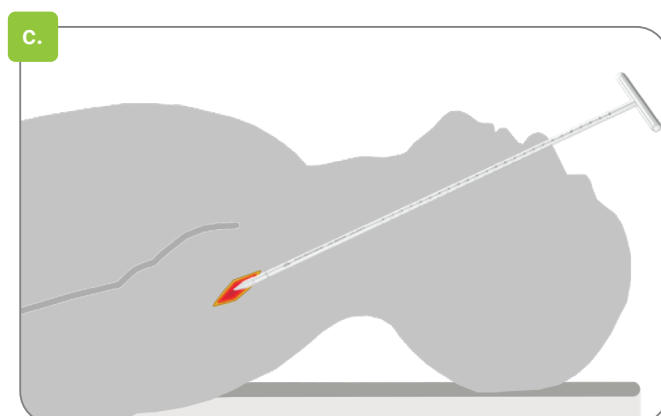
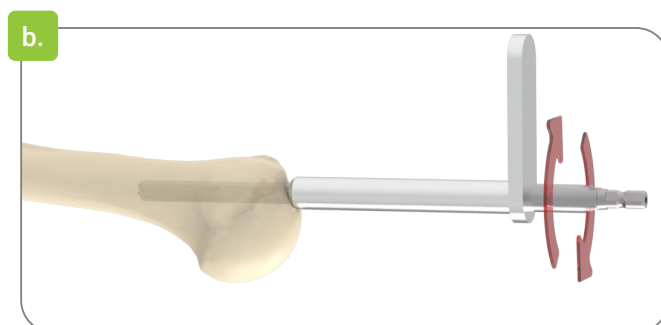
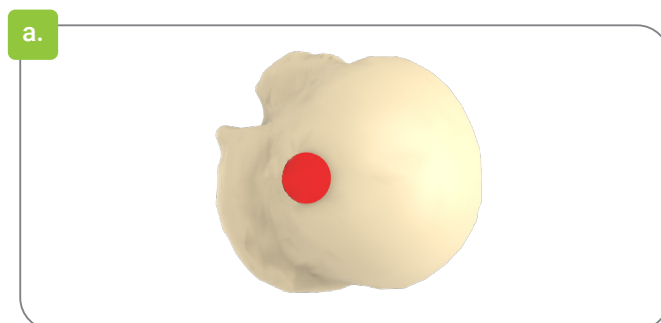

Nail Length

- Select appropriate CHN Long Humeral Nail with suitable diameter and length.
 - » Diameter: Ø7, Ø8 or Ø9mm
 - » Length: 180-260mm (Ø7mm Nails)
200-280mm (Ø8 & Ø9mm Nails)

Nail Length Gauge

Note: If Hand Reaming was used to determine Nail length, skip to Instrument Assembly below.

1. With the Ball-tip Guidewire inserted to the intended position of the nail, pass the Humeral Guidewire Director (600079) over the Guidewire to the Humeral Head.

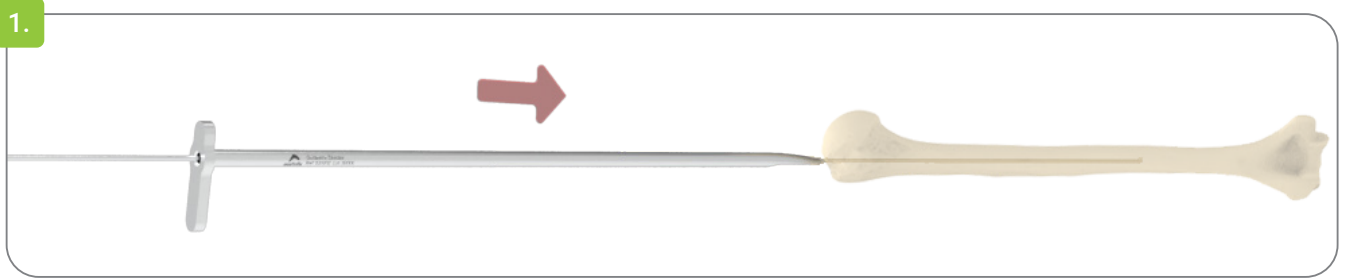

2. Use the Humeral Nail Length Gauge (600069) as shown to determine the appropriate length of Nail.

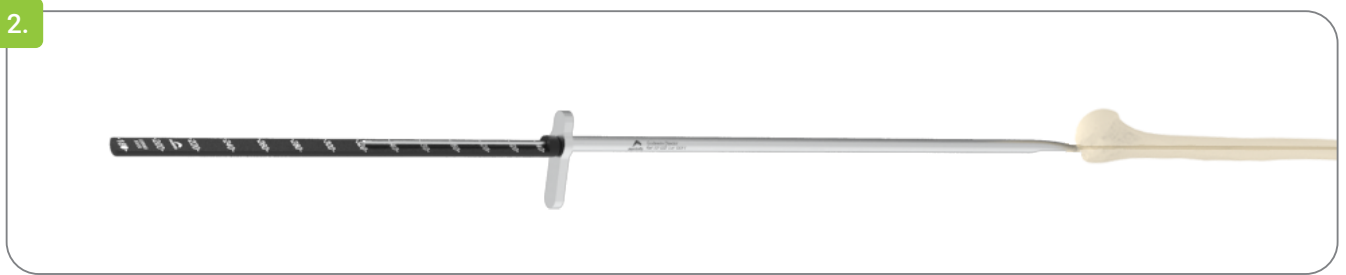

Instrument Assembly

Nail Holder and Impactor

1. Use the 6mm Hex Ball Driver (600045) and Humeral Nail Holding Screw (600076) to stabilise the Cannulated Humeral Nail Holder (600075).
2. With the Nail Holding Screw now fixed, turn the CHN Long onto the Nail Holding Screw.
3. Align so that the inside of the bend of the Nail Holder faces the Cannulated Humeral Nail Holder.
4. Tighten the Cannulated Humeral Nail Holding Screw (600076) with Cannulated 6mm Hex Ball Driver (600045).
5. Regularly check Nail Holding Screw for tightness throughout the operation. If this loosens, screw targeting will not be accurate.
6. The Impactor (600028) must be screwed into the Nail Holder to use a mallet or slap hammer.

Note: Regularly check the Cannulated Nail Holding Screw for tightness throughout the operation. If this loosens, screw targeting will not be accurate.

Warning: Ensure Nail is attached in the correct orientation.

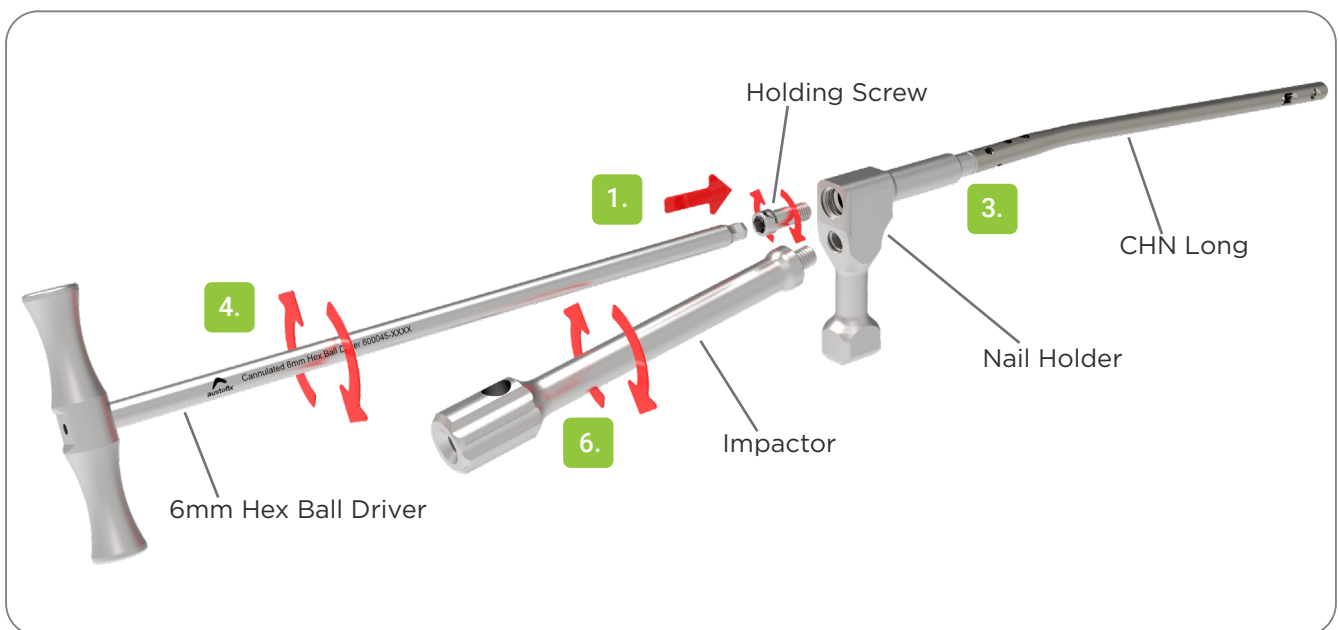
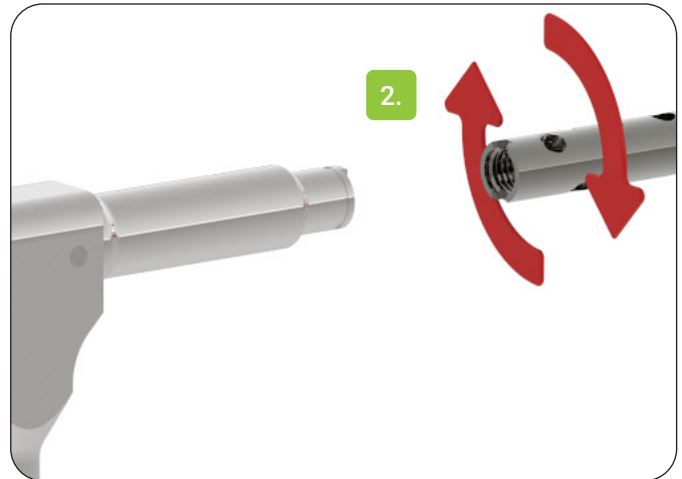

Note: Instrument Assembly for CHN Long shown above.

Nail Insertion

Insert the Nail through the entry hole. Use the impactor if using a mallet or Slide Hammer (600097) (Figure a). There are three reference points to note when making sure the end of the Nail is fully inserted inside the bone:

1. The step in the instrument is designed as a visual rather than a radiological reference. It is 10mm above the end of the Nail (Figure b), and should be placed at the level of the rotator cuff.
2. The instrument tapers to the end of the Nail, and there is a slight difference in diameter between the instrument and the Nail, which appears as a small step. Both the taper and the small step should identify the top of the Nail radiologically.
3. As a final reference, the four proximal Screw holes will be visible on the X-ray image. The most proximal hole should be within 8mm of the top of the Nail, with all four proximal holes within 30mm of the top of the Nail.

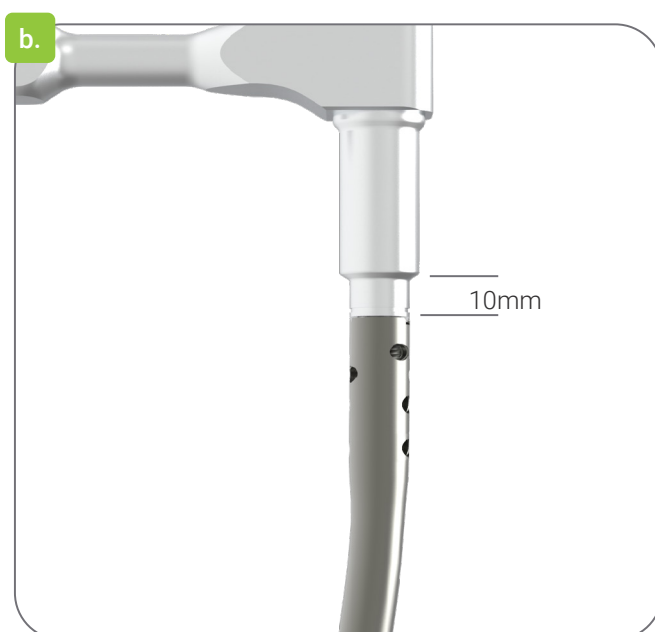
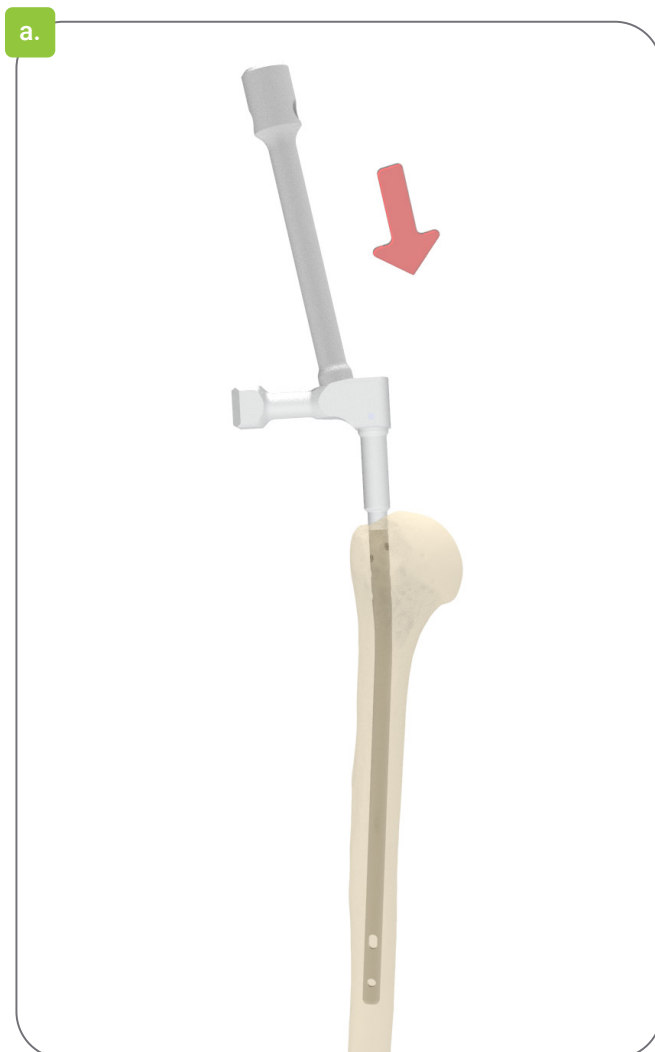

Insertion of Screws

Distal Screws

Distal Screw insertion is done with the elbow fully extended and the arm lying horizontally on a radiolucent board or side table. For Ø7mm Nails, the 3.5mm Locking Screws are to be used with the 3.2 x 240mm Drill (513224). For Ø8 & Ø9mm Nails, use the 4.0mm Locking Screws with the 3.7 x 240mm Drill (513724). The C-arm is positioned with the X-ray beam postero-anterior, which is normally approximately vertical, and with its base in line with the Nail. It is then possible to separately adjust transverse and proximal/distal alignment by the different planes of movement of the C-arm. Either of two methods can be used:

Note: A shorter 3.7 x 155mm Drill (513715) is available upon request for Ø8 & Ø9mm Nails.

Ezy-Aim Distal Targeting

Note: When using the Ezy-Aim Distal Targeting System the distal Screws must be inserted first to ensure the sensor can fit down the Cannulated Humeral Nail.

1. Attach the Cannulated Humeral Nail DTA Adaptor (600077). Ensure the shaft of the Humeral Nail DTA Adaptor is directed anteriorly and the shaft of the Cannulated Humeral Nail Holder is directed laterally with respect to the affected limb.
2. Attach the Humeral DTA Holder (610105) using the 3.5mm Hex Screwdriver (610067).
3. Refer to “700402 Ezy-Aim Surgical Technique” for further details.

Free-Hand

Alternatively free hand technique can also be used.

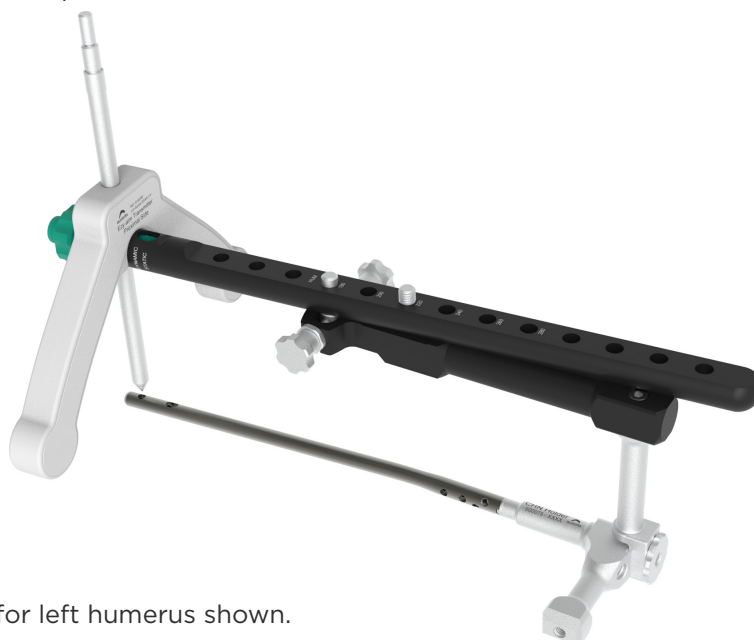
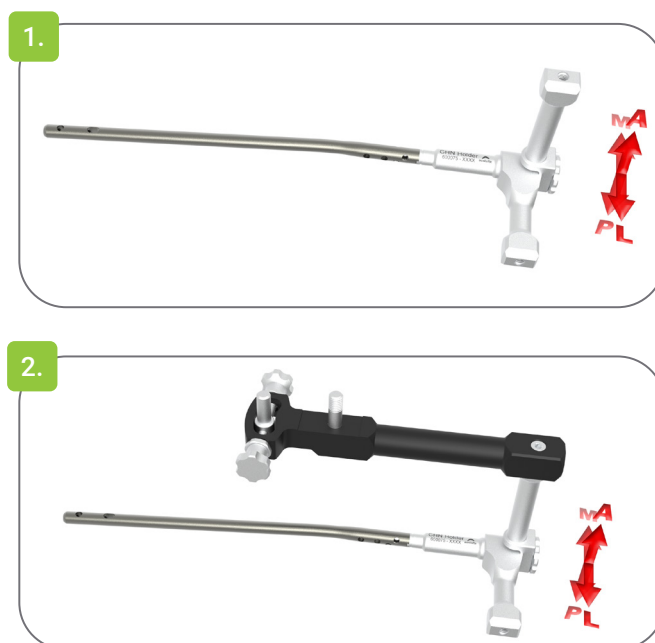

Note: Ezy-Aim assembly for left humerus shown.

Proximal Screws

Check that the Nail and humeral head are in the correct rotary position and the Cannulated Nail Holding Screw (600076) is tight. The lesser tuberosity should face anteriorly and the Cannulated Humeral Nail Holder (600075) laterally.

Note: There is a hole for a K-Wire (512525) in the Proximal Screw Guide that aligns with top of Nail when alignment is correct.

There are four holes for the proximal Humeral Head Screws. For each hole the drilling and Screw placement steps are the same.

1. Attach the Proximal Screw Guide (600078A) to the Cannulated Nail Holder with the 3.5mm Hex Screwdriver (610067). Slide in Short (600078C) and Long (600078B) Locking Sleeves.
2. Insert the 150mm Outer Sleeve (610040) / 150mm Drill Sleeve (610039) / 150mm Trocar (610038) assembly through either of the outlying instrument guide-holes. Make a small stab wound, push the assembly right up to the bone and tighten the Locking Knob. When the Drill Sleeve is against the bone, the Trocar will not pass in the last 2-3mm.

Note: The left guide hole of the instrument is the most proximal one.

3. Remove the Trocar and drill into the humeral head using the 3.7 x 240mm Drill (513724). Check on the Image Intensifier to avoid drilling into the articular surface. Note the depth marking on the drill which indicates Screw length.

Warning: Drill with caution to prevent penetration of the articular surface.

4. Alternatively, the Universal Depth Gauge

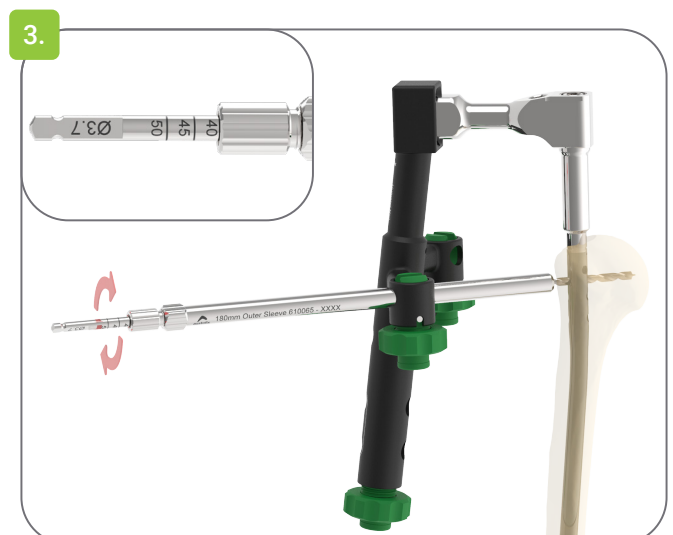
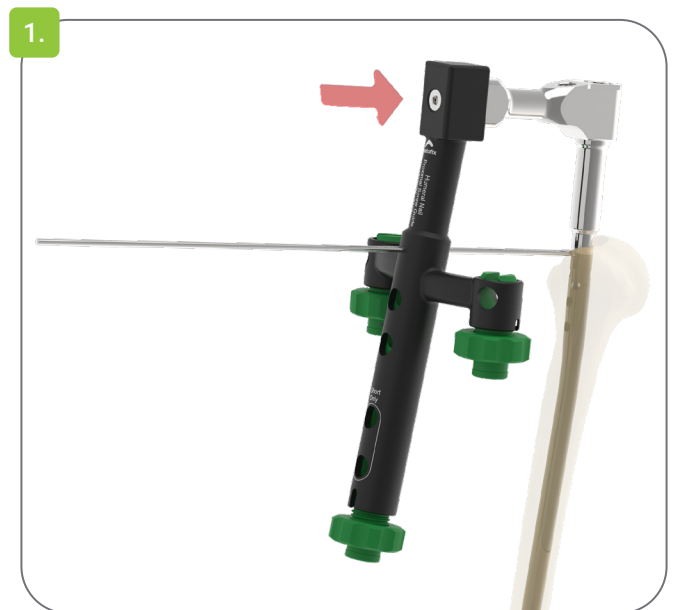

(610069) can be used to determine Humeral Head Screw length. If present, remove the Trocar and 150mm Drill Sleeve. Assemble the Depth Gauge by inserting the Inner Sleeve (610069B) into the Outer Sleeve (610069A) and insert the Depth Gauge through the 150mm Outer Sleeve. Advance the Depth Gauge Outer Sleeve to the cortex and note the depth marking indicating Screw length.

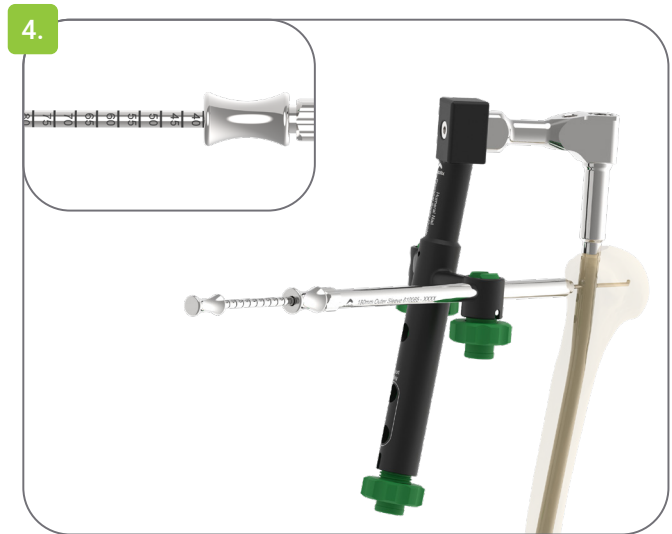

5. Select the Humeral Head Screw of suitable length. Insert using the 3.5mm Hex Power Screwdriver (610068) or by hand using the 3.5mm Hex Screwdriver (610067). The first reference line on the Screwdriver shaft indicates the Screw is fully inserted.

Note: A Titanium Washer (134301) may be used to fix a fractured greater tuberosity.



6. Repeat steps 2-5 for desired proximal Screw configuration.

Note: The two oblique holes should always be used, while the third and fourth lateral holes provide optional extra fixation.

Note: Screws have a “sticky” feel when screwed through the Nail. This is the interference fit which stops backout. Humeral Head Screws can be unscrewed but not re-inserted.

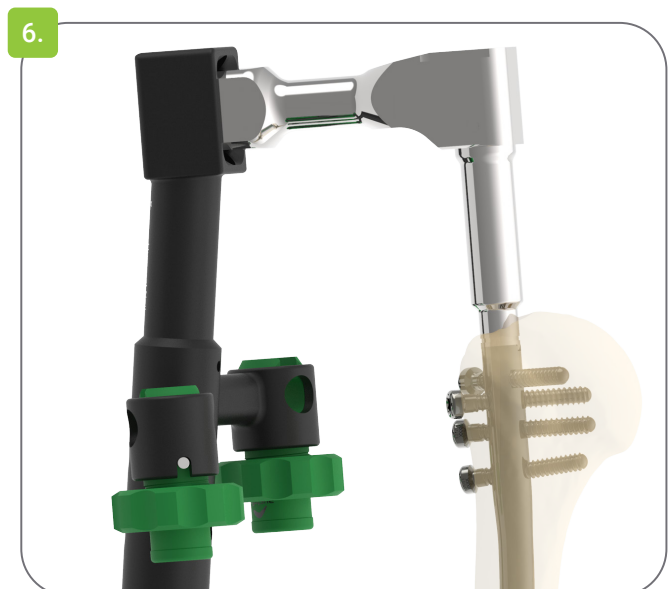

End Cap

An End Cap may be used to deter bone ingrowth or to increase the Nail's length. M7 End Caps can be inserted into the Nail using the 3.5mm Hex 250mm Screwdriver (610067).

Note: End Cap length is determined by surgeons preference. Lengths available include 1, 5, 10, 15 & 20mm.



Aftercare

Initially the arm is supported in a simple sling. Provided stable fixation has been obtained, shoulder mobilising activities should be encouraged as much as pain permits. Activity should remain light for the first 6 weeks.

Nail Extraction

End Caps

- If an End Cap is present, engage and remove with counter-clockwise rotation using the 3.5mm Hex Screwdriver (610067).

M7 Nail Extractor

1. Before incising the rotator cuff, partially unscrew the Humeral Head Screws and estimate where the centre lines of the Screws converge. This will correspond with the centre of the Nail. After finding the Nail, remove the most proximal Humeral Head Screw fully as it can obstruct the Nail Extractor.

Note: The Nail Extractor should be screwed into the Nail before the remaining proximal and distal Screws are removed. This is to avoid unwanted Nail rotation or distal migration.

2. The M7 Nail Extractor (600108) is screwed into the Nail (Figure a).

Humeral Head & Locking Screw Removal

- Austofix Screws are fitted with a conventional 3.5mm hexagonal drive. They can be removed either with the 3.5mm Hex Power Screwdriver (610068) or by hand using the 3.5mm Hex Screwdriver (610067).

Nail Removal

- Attach the Slide Hammer assembly (600097) onto the Nail extractor and withdraw the Nail (Figure b).

Note: When attaching the Slide Hammer onto the Nail Extractor, avoid rotating the Nail inside the humerus.

The instruments required for extraction of Austofix CHN Nails are listed below:

| Product Code | Description |
|--------------|-----------------------------|
| 600108 | M7 Nail Extractor |
| 610067 | 3.5mm Hex Screwdriver |
| 610068 | 3.5mm Hex Power Screwdriver |
| 600097 | Slide Hammer |

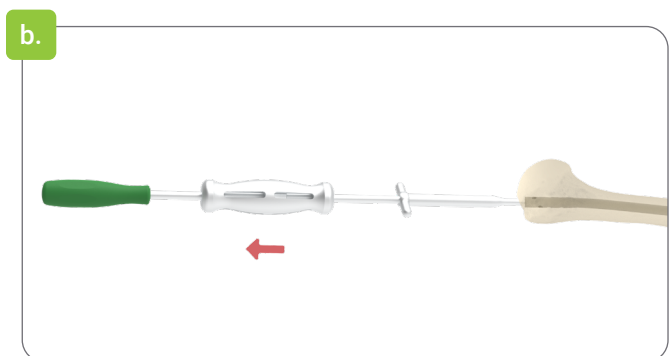
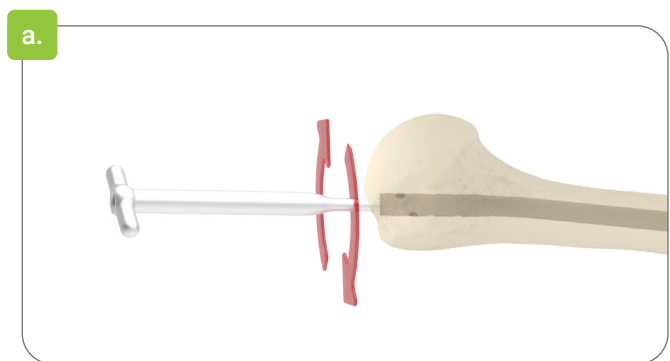

Instruments

Top Layer

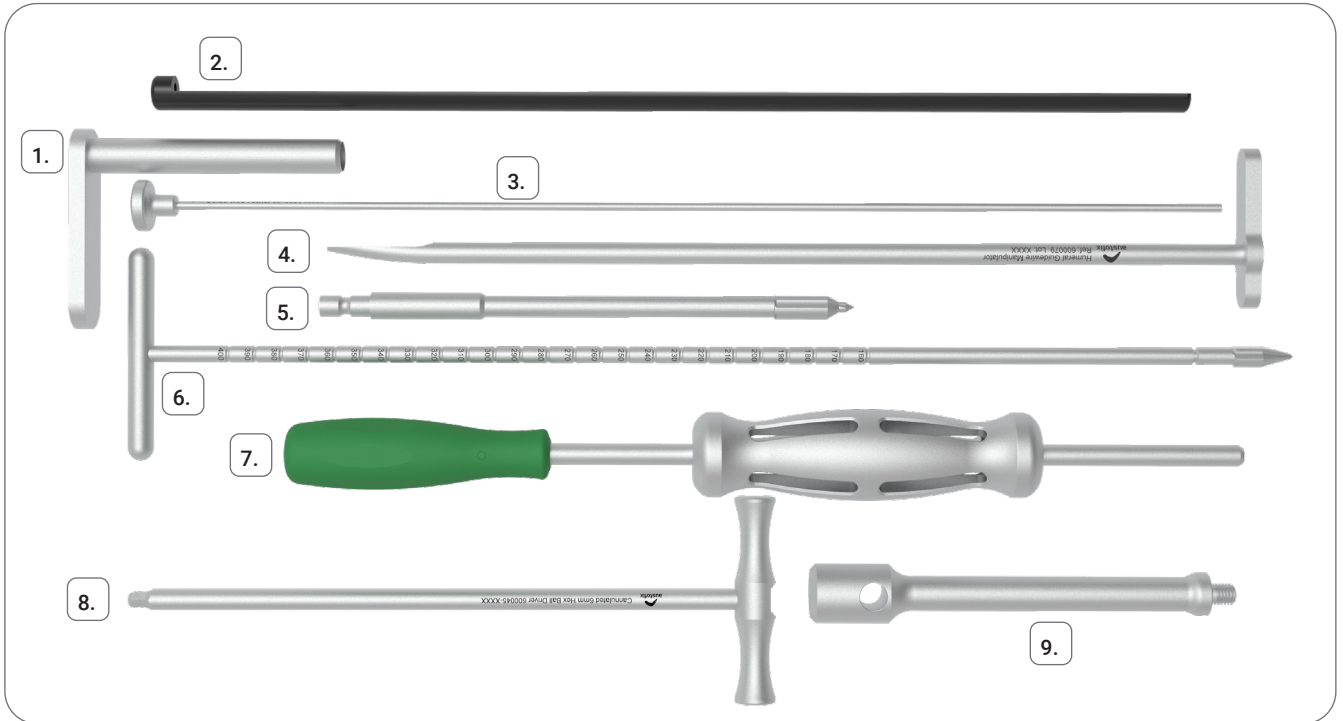

- | | | | | | | | |
|----|--------|---|-----------------------------|----|--------|---|--------------------------------|
| 1. | 600001 | - | 10mm Tissue Guard | 6. | 600008 | - | 8mm Hand Reamer |
| 2. | 600080 | - | Humeral Nail Length Gauge | 7. | 600097 | - | Slide Hammer |
| 3. | 531000 | - | Guidewire Pusher | 8. | 600045 | - | Cannulated 6mm Hex Ball Driver |
| 4. | 600079 | - | Humeral Guidewire Director | 9. | 600028 | - | Impactor |
| 5. | 520921 | - | 9mm Cannulated Drill Reamer | | | | |

Base Layer

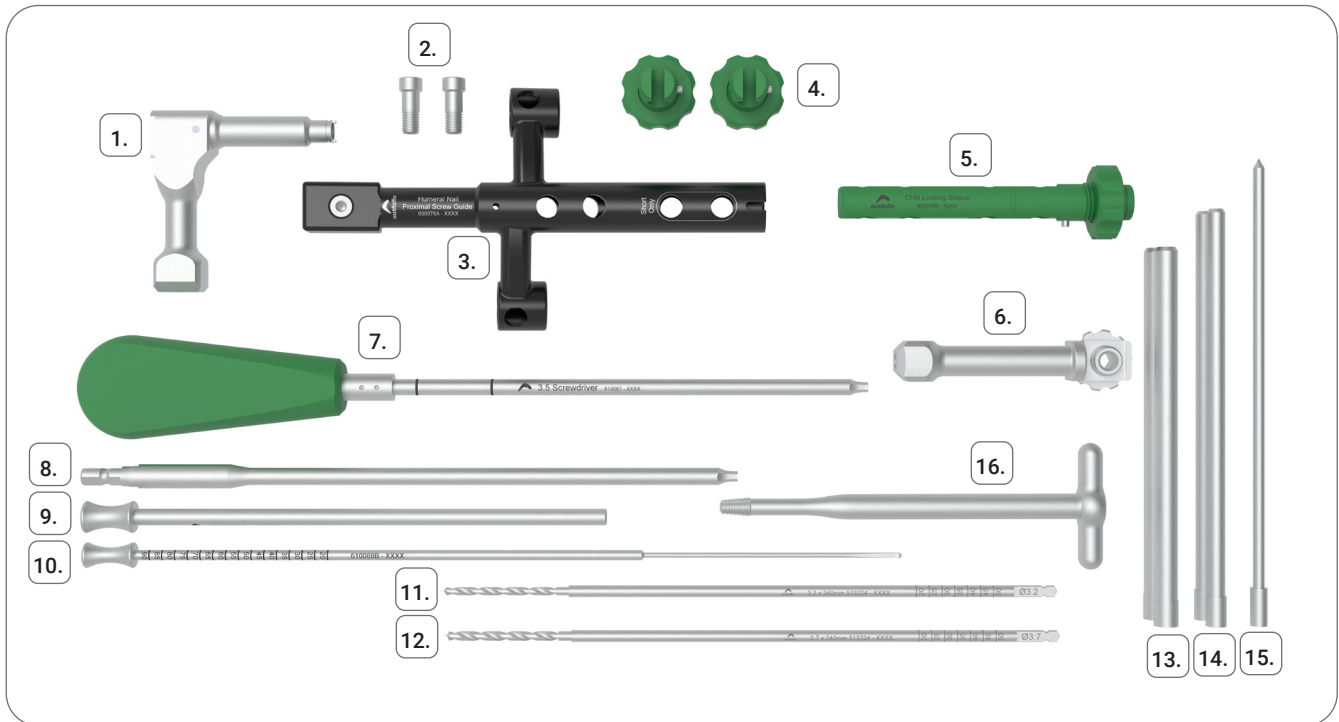

- | | | | | | | | |
|----|---------|---|------------------------------|-----|---------|---|-------------------------------------|
| 1. | 600075 | - | Humeral Nail Holder | 9. | 610069A | - | Depth Gauge Outer |
| 2. | 600076 | - | Humeral Nail Holding Screw | 10. | 610069B | - | Depth Gauge Inner |
| 3. | 600078A | - | CHN Proximal Screw Guide | 11. | 513724 | - | 3.7x240mm Drill (4.0 & 4.3mm Screw) |
| 4. | 600078C | - | CHN PSG Locking Sleeve Short | 12. | 513224 | - | 3.2x240mm Drill (3.5mm Screw) |
| 5. | 600078B | - | CHN PSG Locking Sleeve Long | 13. | 610040 | - | 150mm Outer Sleeve |
| 6. | 600077 | - | Humeral Nail DTA Adaptor | 14. | 610039 | - | 150mm Drill Sleeve |
| 7. | 610067 | - | 3.5 Hex Screwdriver | 15. | 610038 | - | 150mm Trocar |
| 8. | 610068 | - | 3.5 Power Screwdriver | 16. | 600108 | - | M7 Nail Extractor |

Single Use Items

Guidewire

| Product Code | Description |
|--------------|----------------------------------|
| 512525 | 2.5 x 250mm K Wire (Twin Packed) |
| 533900 | 3.0 x 900mm Ball-tip Guidewire |



Drill

| Product Code | Description |
|--------------|--|
| 513224 | 3.2 x 240mm Drill (for 3.5mm Screw) |
| 513724 | 3.7 x 240mm Drill (for 4.0 & 4.3mm Screw) |
| 513715 | 3.7 x 155mm Drill (Optional for 4.0mm Screw) |



Implants - Titanium

| CHN Long - Titanium | |
|---------------------|--------------|
| Nominal Length | Product Code |
| Ø7 | |
| 180 | 130718 |
| 200 | 130720 |
| 220 | 130722 |
| 240 | 130724 |
| 260 | 130726 |
| Ø8 | |
| 200 | 130820 |
| 220 | 130822 |
| 240 | 130824 |
| 260 | 130826 |
| 280 | 130828 |
| Ø9 | |
| 200 | 130920 |
| 220 | 130922 |
| 240 | 130924 |
| 260 | 130926 |
| 280 | 130928 |



| M7 End Cap | |
|--------------|------------|
| Product Code | Cap Length |
| 190701 | 1 |
| 190705 | 5 |
| 190710 | 10 |
| 190715 | 15 |
| 190720 | 20 |



| Washer for Humeral Head Screws | |
|--------------------------------|--|
| Product Code | |
| 134301 | |

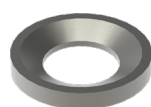

| 4.0mm Locking Screw | |
|---------------------|--------------|
| Product Code | Screw Length |
| 364020 | 20 |
| 364025 | 25 |
| 364030 | 30 |
| 364032 | 32.5 |
| 364035 | 35 |
| 364037 | 37.5 |
| 364040 | 40 |
| 364042 | 42.5 |
| 364045 | 45 |
| 364047 | 47.5 |
| 364050 | 50 |
| 364055 | 55 |
| 364060 | 60 |
| 364065 | 65 |
| 364070 | 70 |



| 4.3mm Humeral Head Screw | |
|--------------------------|--------------|
| Product Code | Screw Length |
| 134325 | 25 |
| 134327 | 27.5 |
| 134330 | 30 |
| 134332 | 32.5 |
| 134335 | 35 |
| 134337 | 37.5 |
| 134340 | 40 |
| 134342 | 42.5 |
| 134345 | 45 |



| 3.5mm Locking Screw | |
|---------------------|--------------|
| Product Code | Screw Length |
| 133520 | 20 |
| 133525 | 25 |
| 133530 | 30 |



MRI Safety

Austofix has not evaluated its devices for safety and compatibility in a Magnetic Resonance (MR) environment. However, the materials used in their manufacture are known to have minimal ferromagnetism, with minimal risk to patients in strong magnetic fields.

Austofix has performed a review of published, peer-reviewed data, which confirms that only minor rises in MRI-related heating are observed from devices manufactured from the same titanium materials. Trauma devices are considered unlikely to produce injury to patients, including in the worst-case 3.0T systems.

The devices and materials observed in the literature experience forces too weak to cause significant displacement; the risk being further mitigated by their implantation in bone. Risks of imaging artifacts are known to MRI operators, and can be reduced by choosing appropriate pulse sequences and optimizing scanning parameters by using a large bandwidth, small field-of-view and appropriate echo train length.

Average temperature changes have been observed in studies at 0.48°C. Rises in temperature in clinical situations may depend on individual patient factors. It should be recommended that patients be thoroughly monitored when undergoing MR scanning, and that impaired patient thermoregulation be considered a contraindication for MRI procedures.

Sources:

Chen CA, Chen W, Goodman SB, et al. New MR Imaging Methods for Metallic Implants in the Knee: Artifact Correction and Clinical Impact. 2011, 1121-1127.

Gill A, Shellock FG. Assessment of MRI issues at 3-Tesla for metallic surgical implants: findings applied to 61 additional skin closure staples and vessel ligation clips. *J Cardiovasc Magn Reson.* 2012, 14(1):3.

Shellock FG. Biomedical Implants and Devices: Assessment of Magnetic Field Interactions With a 3.0-Tesla MR System. 2002, 721-732.

Zou Y, Chu B, Wang C, Hu Z. Evaluation of MR issues for the latest standard brands of orthopedic metal implants, Plates and screws. *Eur J Radiol.* 2015, 84(3):450-457.

Notes



austofix

Legal Manufacturer

Australian Orthopaedic Fixations Pty Ltd
18 Kinkaid Avenue, North Plympton SA 5037, AUSTRALIA

Telephone: 1300 727 075
Fax: 1300 727 380
Email: sales@austofix.com.au

DISTRIBUTOR STICKER